

3.25" Post and Panel System

ABC's Better Idea

There are other Post and Panel systems on the market, but ABC wanted something new and different that offered significant advantages and savings for our customers. First, for companies that build a lot of these signs, our system costs less; 15% to 20% less for the stock length extrusions than competing systems. But that's not all.

Second, they are assembled almost entirely with ABC's patented Corner Keys. So whether you build these signs or we build them for you, they require substantially less labor, which is another big savings.



The Post and Panel Corner Keys are strong, die-cast metal with (removable) spring steel clips on each end. When pressed into place, they cannot be withdrawn. However, if the spring steel clips are removed from one side of the corner key, the assembly can then come apart. The Corner Keys are press fit into close tolerance slots in the extrusions for assembling 90-degree mitered corners with no visible hardware and no welding.

Third, conceptually ABC's Post and Panel System is different and better because with just twelve extrusion parts a variety of signs can be built with variations of aesthetic effects. Three different "Reveal" parts are used to slide the frames to the Posts, and each Reveal gives a different appearance.



Just see how these parts are assembled in the centerfold illustrations and you will see how clever they really are! Whether you buy stock lengths, pre-cut kits or have us build them for you, your cost will be much less!

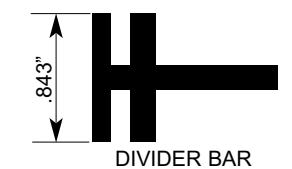
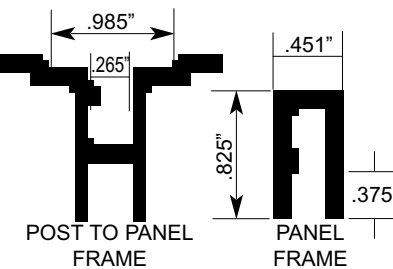
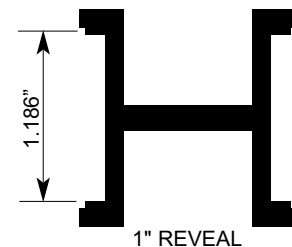
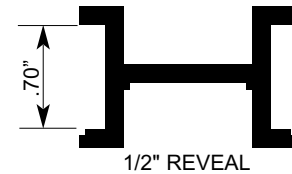
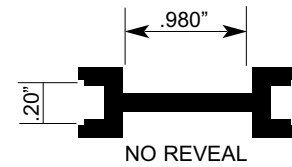
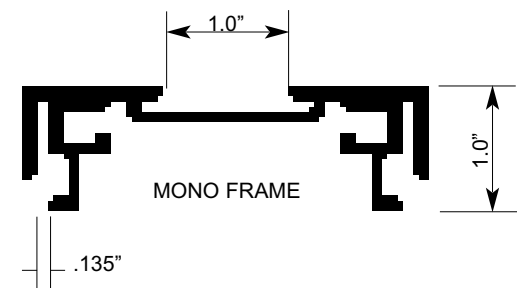
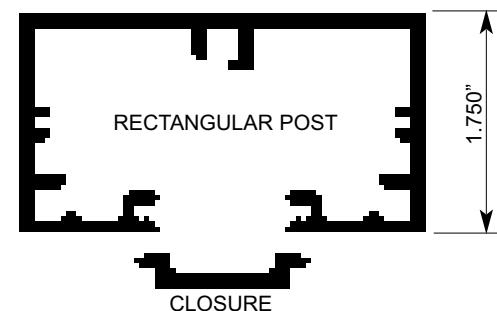
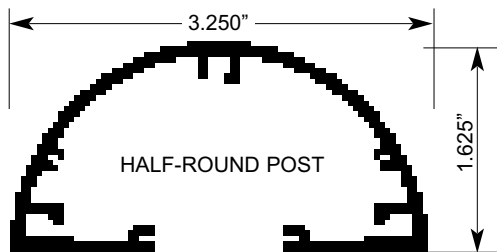

Illuminated 5" Post and Panel System

Internally illuminated Post and Panel signs are made with ABC's 5" Half-Round Posts and **TYPE IV FRAME** parts, joined together with either **NO REVEAL**, the **1/2"** or **1"** **REVEAL** as illustrated at right. (Fig.1)

If the 5" post is also to be used as a header at the top of the sign, three Post and Panel Corner Keys at each end attach it to the upright Posts. (Fig.2)

The Reveal is bolted to the Frame, (Fig.3) and the Post slides in place, (Fig.4)

The **Type IV Unit Frame** is used on the vertical sides and the **Type IV End Frame** is used on the top and bottom with removable Retainers for installing the face and to service the internal lighting system.

If there is no header, the 5" Posts are square cut at the top of the sign and Post Caps are used as illustrated (Fig.5)

This Type IV Frame assembly is also very popular for smaller illuminated cabinets with routed aluminum faces with push-through plastics.

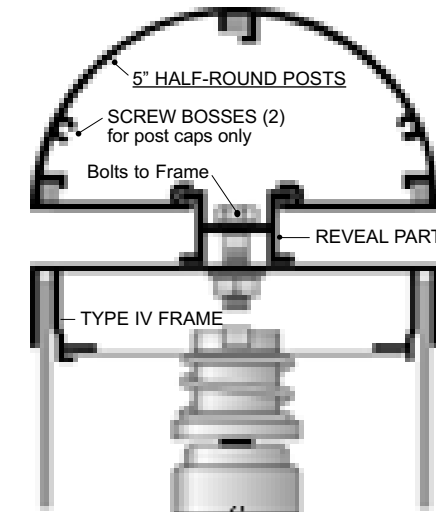

(Fig. 1)

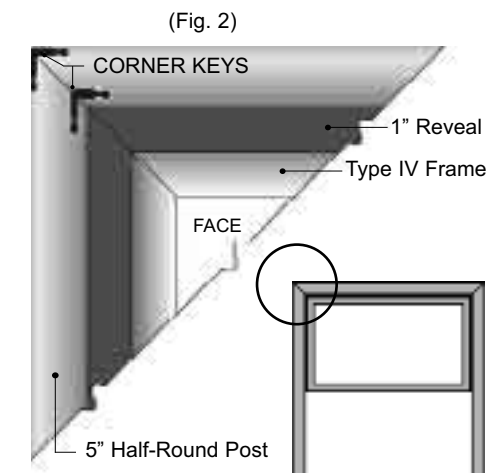

(Fig. 2)



(Fig.3) Bolt Reveal to Frame



(Fig.4) Slide Post in Place



(Fig.5) Install Machined Post Caps

Engineering

5" Half-round Post

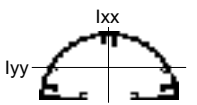

Moment of Inertia	Section Modulus	Radius of Gyration
$I_{xx} = 4.58 \text{ in}^4$	$S_x = 1.83 \text{ in}^3$	$T_x = 1.65 \text{ in}$
$I_{yy} = 1.43 \text{ in}^4$	$S_{yt} = 1.01 \text{ in}^3$	$T_y = 0.914 \text{ in}$
	$S_{yb} = 1.32 \text{ in}^3$	

Type IV Unit Frame

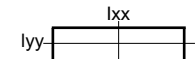

Moment of Inertia	Section Modulus	Radius of Gyration
$I_{xx} = 2.70 \text{ in}^4$	$S_x = 1.07 \text{ in}^3$	$T_x = 1.91 \text{ in}$
$I_{yy} = 0.124 \text{ in}^4$	$S_y = 0.339 \text{ in}^3$	$T_y = 0.408 \text{ in}$

- For building larger Post & Panel signage
- Internally Illuminated or non-illuminated
- Routed aluminum with push-thru graphics
- Suitable for direct embedment installation
- Will support 4' X 8' sign up to 9' height
- Stock lengths, kits or complete signs



Visit our Website to review all of ABC's fine products...
Designed by Sign People for Sign People!

www.abcsignproducts.com

1-800-249-9889



EXTRUSIONS... The Original - and Still the Best!

1-800-248-9889

FAX: 970-482-4019 • 2028 S.E. Frontage Rd., Fort Collins, CO 80525

3.25" Post and Panel System 1/2 Size Section Drawings

■ = LOCATIONS FOR POST AND PANEL CORNER KEYS

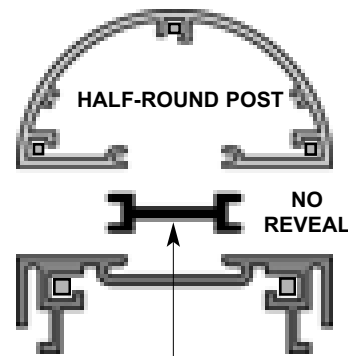

MONO-FRAME
for 1/8" plastic or
aluminum faces

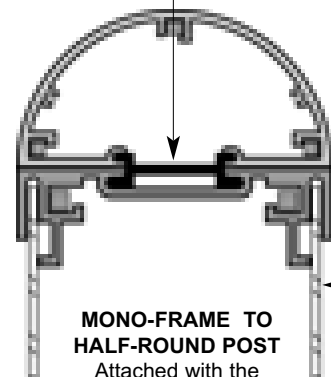

**MONO-FRAME TO
HALF-ROUND POST**
Attached with the
NO REVEAL part, which
connects the frame flush
to the post, giving a
monolithic appearance.

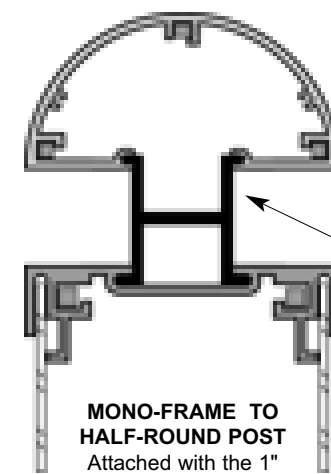

**MONO-FRAME TO
HALF-ROUND POST**
Attached with the 1"
REVEAL part, leaving a
1" wide by 1" deep
reveal between Post
and Frame.

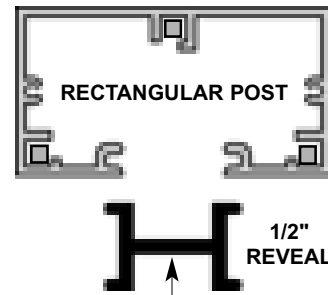

1/2" REVEAL

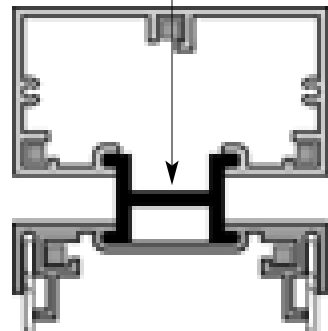

**MONO-FRAME TO
RECTANGULAR POST**
Attached with the 1/2"
REVEAL part, leaving a
1/2" wide by 1" deep
reveal between the post
and frame.

CLOSURE
The CLOSURE part slides
into the POSTS and both
FRAMES
to fill the attachment slots
wherever they are exposed.

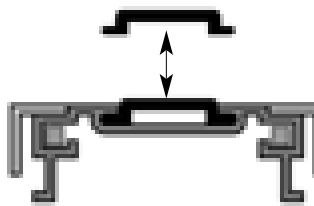

1" REVEAL

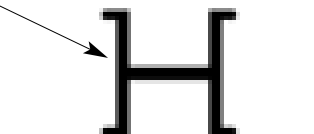

END FRAME
Used on one side with
removable Retainers and
the CLOSURE part.

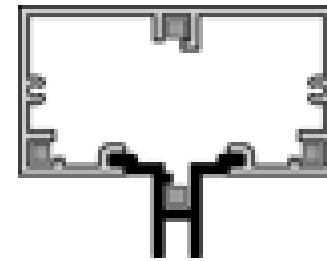

POST TO PANEL FRAME
Used for mounting a single 1/4" thick
sign panel in a flag-mount, or
between two posts, or for hanging
ceiling mount.

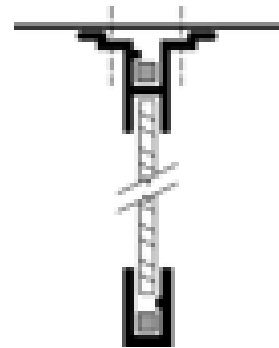

PANEL FRAME
The PANEL FRAME is used for
those sides of a single 1/4" sign
panel not held by the POST-TO-
PANEL frame.



3.25" & 5" POST AND PANEL ASSEMBLY EXAMPLES

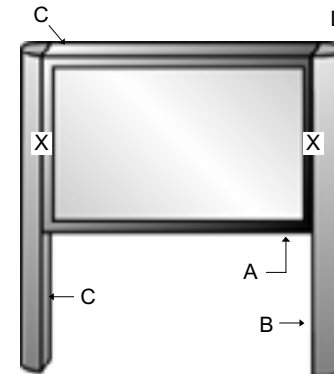

TYPE A: NO HEADER

As illustrated, the MONO FRAME (A) is attached to the HALF-ROUND or RECTANGULAR POST (B) with the NO REVEAL, (X). The CLOSURE part, (C) fills the opening on the inside face of the posts below the sign to, or below grade, and the top and the bottom of the exposed Mono Frame. The precision routed Post Caps (D) finish the assembly. Note: The END FRAME with Removable Retainers can be used on the top or bottom to be able to remove or change the faces.

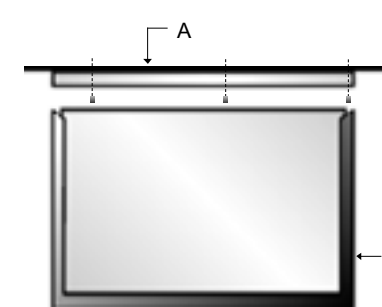

TYPE C: SUSPENDED PANEL

As illustrated, the POST-TO- PANEL frame (A) is attached to the ceiling with screws. The sign face panel is inserted into the PANEL FRAME (B) on the other three sides. The whole frame is assembled with Corner Keys. To ensure against the possibility of the sign coming out of the Frame (A) from which it is suspended, place two screws through the side of the Frame (A) into the face panel.

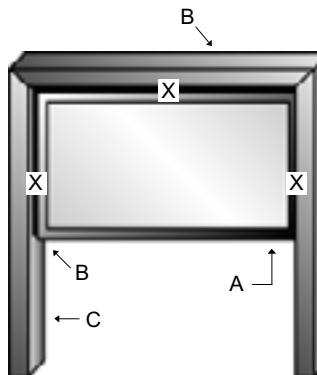

TYPE B: WITH HEADER

As illustrated, the MONO FRAME (A) is attached to the RECTANGULAR or HALF ROUND POSTS AND HEADER (B) with the 1" REVEAL (X). The CLOSURE (C) fills the opening on the inside face of the posts below the sign to, or below grade. Note: The End Frame with removable Retainers may be used on the bottom top to be able to change faces.

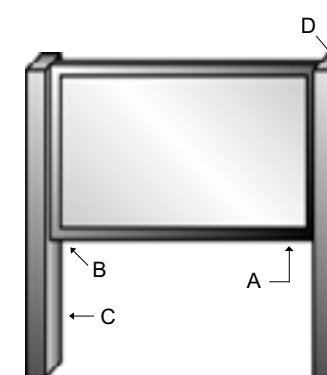

**TYPE D: DOUBLE POST- SINGLE
PANEL**

As illustrated, the face panel is framed with the PANEL FRAME (A) top and bottom, and the POST-TO-PANEL FRAME (B) on each end, all assembled with Corner Keys. The Post-To-Panel Frame on the ends slides into the Posts. The CLOSURE (C) fills the openings on the posts below the sign. The POST CAPS (D) finish the tops of the posts and prevents the sign from being lifted out.

Accessories

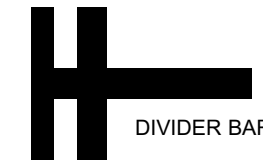

Used with the MONO-FRAME and END FRAME to separate face panels and make them changeable as may be required.

POST AND PANEL CORNER KEYS
Are furnished by ABC. Only one size is required for all Post & Panel parts assembly. Note Corner Key slots on all the illustrations.



POST CAPS
The aluminum Post Caps are precision made on ABC's routing machines. They attach to the Post tops with two #6 phillips panhead screws into the extruded screw bosses inside the posts.

Engineering

3.25" Half-Round Post

Moment of Inertia	Section Modulus	Radius of Gyration
$I_{yy} = 1.075 \text{ in}^4$	$S_{yy} = 0.661 \text{ in}^3$	$r_y = 1.076"$
$I_{xx} = 0.281 \text{ in}^4$	$S_{xx} = 0.308 \text{ in}^3$	$r_x = 0.55"$

3.25" Rectangular Post

Moment of Inertia	Section Modulus	Radius of Gyration
$I_{yy} = 1.530 \text{ in}^4$	$S_{yy} = 0.940 \text{ in}^3$	$r_y = 1.20"$
$I_{xx} = 0.483 \text{ in}^4$	$S_{xx} = 0.529 \text{ in}^3$	$r_x = 0.673"$

3.25" Mono-Frame

Moment of Inertia	Section Modulus	Radius of Gyration
$I_{yy} = 1.08 \text{ in}^4$	$S_{yy} = 0.665 \text{ in}^3$	$r_y = 1.14"$
$I_{xx} = 0.05 \text{ in}^4$	$S_{xx} = 0.073 \text{ in}^3$	$r_x = 0.245"$

3.25" End Frame

Moment of Inertia	Section Modulus	Radius of Gyration
$I_{yy} = 0.61 \text{ in}^4$	$S_{yy} = 0.437 \text{ in}^3$	$r_y = 1.00"$
$I_{xx} = 0.038 \text{ in}^4$	$S_{xx} = 0.058 \text{ in}^3$	$r_x = 0.25"$