

WIND SPEED AND DESIGN CRITERIA FOR FLEXIBLE FACE SIGNS CONSTRUCTED OF ABC EXTRUSIONS

2005 EDITION

This edition is based upon ASCE 7-98 recommendations for wind speed and wind loads. These have changed since the last edition of this criteria was published by ABC. The new edition also includes valuable new information for the proper selection and use of steel plates and bolts for connecting ABC extrusions to center pole mounted signs.

Copyright, 2005. All rights reserved by ABC Signs Products, Inc.



2028 S.E. Frontage Road, Fort Collins, Colorado 80525 • 1.800.248.9889 • FAX 970.482.4019

web address: www.abcsignproducts.com

email: abcsigns@abcsignproducts.com

WIND SPEED AND DESIGN CRITERIA FOR FLEXIBLE FACE SIGN CONSTRUCTION WITH ABC EXTRUSIONS.

This is your reference source to build sign cabinets from the ABC A/Flexframe assemblies to properly support flexible face for any given wind-load which may be required.

NOTE: This information is intended to assist sign designers and sign builders in the proper construction of these assemblies. These guidelines are suitable for signs up to 250 square feet per face. Complete sign design should be reviewed by a certified structural engineer for signs larger than 250 square feet in area.

The structural strength of any sign cabinet with flexible face is extremely important. Unlike rigid plastic face, which are merely suspended on the frame, (free to expand and contract), flexible faces are attached to the frame much like a drumhead, and the tension load plus the total wind-load is imposed upon the minor axis of the frame.

By using simple engineering formulae, the ABC A/Flexframes are easy and economical to build to meet any required wind-load, with much less internal bracing than would be required for angle iron and sheet metal construction.

Three items of information are required to determine the proper structural design of the A/Flexframe for the installation of flexible faces.

1. Local wind load requirements based upon the Isotac map (Below).
2. The Distance from grade to the top of the sign cabinet.
3. Wind speed and design criteria.

Notes:

1. Values are 3 second gusts speeds in MPH at 33 feet above ground for Exposure C category and are associated with an annual probability of 0.02.
2. Linear interpolation between wind speed contours is permitted.
3. Islands and coastal areas shall use wind speed contour of coastal area.
4. Mountainous terrain, gorges, ocean promontories, and special wind regions shall be examined for unusual wind conditions.

To properly design the application of our A/Flexframe assemblies, please be sure that all the following steps are taken:

1. Determine the wind velocity from the Isotac Map for your area.
2. Determine the Design Wind Pressure from the table below, or obtain that information from local building codes.

DESIGN WIND PRESSURE TABLE

Distance from Ground To Top of Sign Cabinet Design Wind Pressure (Pounds per square Ft.)

	90 MPH	100 MPH	110 MPH
15 to 30 Feet	30 PSF	35 PSF	45 PSF
31 to 50 Feet	35 PSF	45 PSF	55 PSF
51 to 100 Feet	40 PSF	50 PSF	60 PSF
101 to 150 Feet	45 PSF	55 PSF	65 PSF
151 to 200 Feet	50 PSF	60 PSF	70 PSF

EXCEPTIONS:

- A. S/F Fascia signs may be designed for 5 PSF less than shown.
- B. The table is a general reference minimum and does not apply to known special wind regions requiring greater design pressure.
- C. **Local Building Codes shall supersede the table values.**

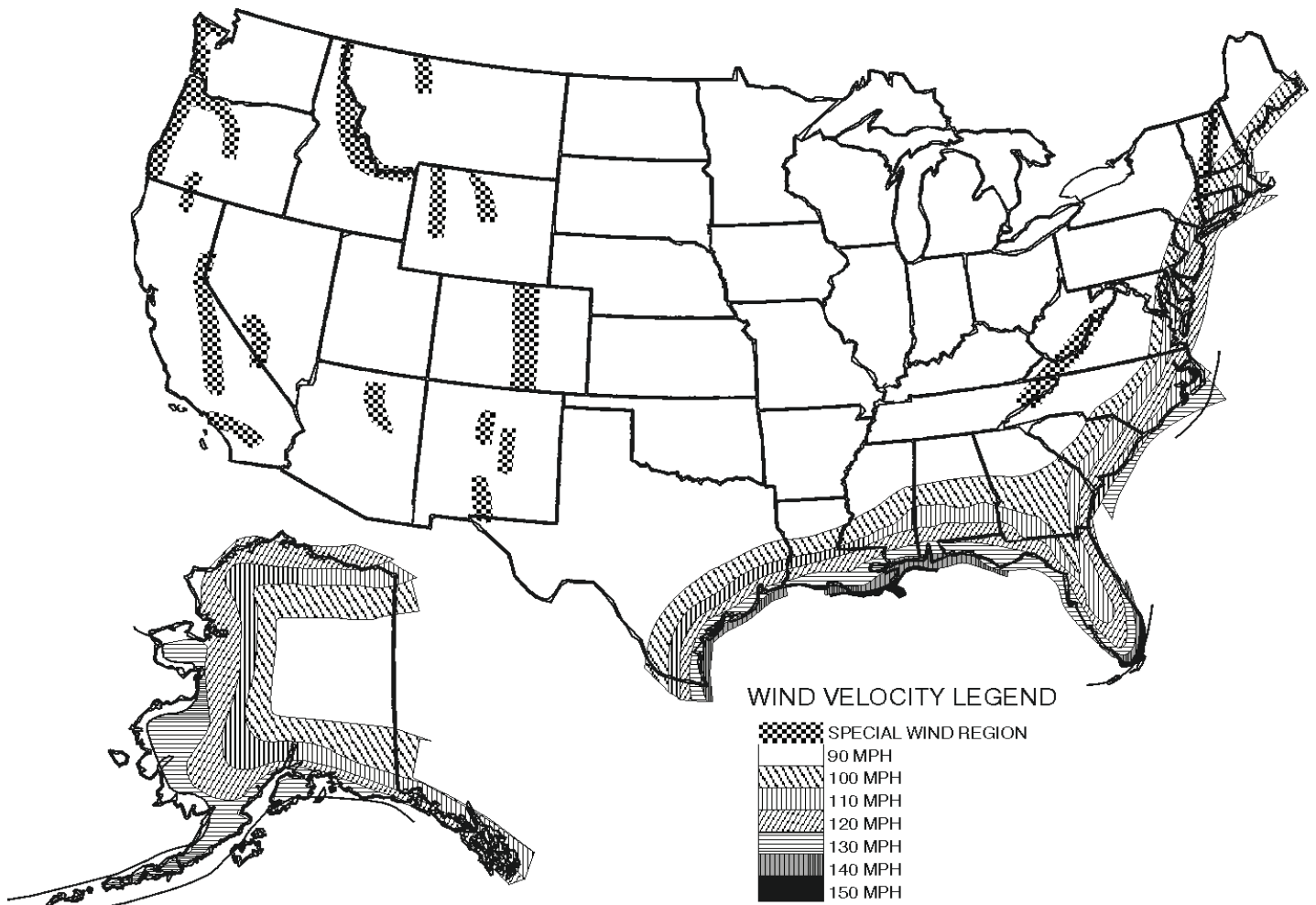

3. Calculate the Perimeter Bending Force (on the frame) by using the following formula. $W = \frac{A \times P}{L} + 30$

WHERE:

- W = Perimeter Bending Force (lbs/ft.)**
- A = Area of Sign (square feet per face)**
- P = Design Wind Pressure (lbs/sq ft.)**
- L = Perimeter of the sign Frame (feet)**

4. Determine the maximum span between structural strut (braces) for the perimeter of the sign cabinet using the **MAXIMUM SPAN BETWEEN STRUTS TABLE** (below). Reading across the top of the table, locate the Perimeter Bending Force as calculated in step 3. The distance, in inches, listed in the column below the PBF is the maximum span between struts.

MAXIMUM SPAN, IN INCHES, BETWEEN STRUCTURAL STRUTS OR SUPPORT MEMBERS

Perimeter Bending Force Span (inches)	<u>80</u>	<u>100</u>	<u>120</u>	<u>140</u>	<u>160</u>	<u>180</u>	<u>200</u>	<u>220</u>	<u>240</u>	<u>260</u>
Large A/Flexframe	94"	87"	82"	78"	74"	72"	69"	67"	65"	63"
Small A/Flexframe	98"	90"	85"	81"	77"	74"	72"	69"	67"	66"
2 x 2 x 3/16" Steel L Frame	73"	66"	60"	55"	52"	49"	46"	44"	42"	41"

5. Based upon the Perimeter Bending Force, select the proper spacing of tensioners from the chart below for attaching the flexible face to the frame. Follow the instruction for proper tensioning as found in the ABC Easy Sheet #1.

TENSIONER HARDWARE SPACING:

(Based upon Perimeter Bending Force)

Up to 100 lbs/ft.	12" centers, maximum
101 - 110 lbs/ft.	11" centers, maximum
111 - 130 lbs/ft.	10" centers, maximum
131 - 150 lbs/ft.	9" centers, maximum
151 - 200 lbs/ft.	8" centers, maximum
201 - 300 lbs/ft.	7" centers, maximum
301 - 500 lbs/ft.	6" centers, maximum

6. To select the proper size support member for each strut, determine the net length of the strut required, in inches, from one inside edge of the frame to the inside edge of the opposite frame, or from the inside edge of the frame to a RIGID internal member, such as a pipe or tube used as the main support column, and divide that length by 150. This resulting number equals the RADIUS OF GYRATION. (r)

$$r = \frac{l}{150}$$

WHERE: r = Radius of Gyration

l = Length of strut member, (inches)

As an example, for a strut 82" long, $r = 82/150 = 0.55$

From a table of properties for steel angles and square tubes, under the column Z-Z axis for angles, (r), or the Radius of Gyration column for square tubes or angles, the proper size and wall thickness for a angle or square tube strut may be selected. A quick reference chart is provided below for your convenience.

**QUICK REFERENCE CHART FOR INTERNAL STRUT MEMEBERS
ASTM -36 STEEL OR 6061-T6 ALUMINUM**

STRUT LENGTH	STEEL ANGLE	ALUM. ANGEL	STEEL SQ. TUBE	ALUM. SQ.TUBE
0 to 45 inches	1.5 x 1.5 x .125"	1.5 x 1.5 x .125"	1 x 1 x .083"	1 x 1 x .083"
46 to 60 inches	2 x 2 x .125"	2 x 2 x .125"	1.25 x 1.25 x .083"	1.25 x 1.25 x .125"
61 to 72 inches	2.5 x 2.5 x .188"	2.5 x 2.5 x .188"	1.25 x 1.25 x .083"	1.25 x 1.25 x .125"
73 to 84 inches	3 x 3 x .188"	3 x 3 x .25"	1.5 x 1.5 x .083"	1.5 x 1.5 x .125"
85 to 114 inches	3.5 x 3.5 x .25"	4 x 4 x .25"	2 x 2 x .083"	2 x 2 x .125"
115 to 144 inches	4 x 4 x .25"	4 x 4 x .25"	3 x 3 x .188"	3 x 3 x .25"

From the above chart, it is obvious that angels are much heavier, more costly and larger, which can create shadows and lamp spacing problems. At ABC, we recommend the use of steel square tubes for internal structural struts. Inventory control can be simplified by stocking 1" inch, 1-1/4", 1-1/2" inch, 2 inch and 3 inch square tubes for this purpose.

By prefabricating the strut brackets and C-iron brackets used to attach these struts to the extruded aluminum frames in quantities of 50 to 100 units at a time, a company can minimize the cost of the brackets and maximize labor efficiency associated with constructing struts inside extruded aluminum sign frames.

GUIDELINES FOR USING DEFLECTION CABLES FOR FLEXIBLE FACES

IMPORTANT NOTE: For signs over 10 ft. tall and also over 220 sq. ft. per face, use 1/8 inch diameter vinyl-coated aircraft cable in a rectangular grid (not to exceed 6 ft. x 6 ft. spacing) to limit face deflection. This helps to limit stress on the face substrate, the tensioning system and the sign frame. Attached the cables using small turnbuckles approximately 3 inches back from the inside surface of the flexible face. It is best to attach the turnbuckles using small eye-bolts through the c-irons or strut brackets which are used to reinforce the extrusion. It is critical to use vinyl-coated cable to prevent marking or damaging the inner surface of the face. These cables should be installed just tight enough to take all the slack out of the cables, but should **not** be pulled any tighter. For signs over 300 sq. ft. in area, use ABC's Large Flex Joint.

SUPPORT PLATE SCHEDULE FOR CENTER POLE MOUNT SIGNS

DOUBLE-FACE ABC LARGE A/FLEXFRAME ASSEMBLIES FOR SIGNS WITH LENGTHS 4 TIMES THEIR HEIGHT: (4 TO 1 ASPECT RATIO)

Sign size : No Greater Than	PIPE SIZE	35 PSF WIND LOAD			45 PSF WIND LOAD			55 PSF WIND LOAD		
		BOLT SIZE	PLATE THICKNESS	PLATE TYPE	BOLT SIZE	PLATE THICKNESS	PLATE TYPE	BOLT SIZE	PLATE THICKNESS	PLATE TYPE
6' - 4 1/2" X 25' - 0"	6" H.W.	1/2"	5/8"	C	5/8"	3/4"	C	5/8"	3/4"	C
5' - 4 1/2" X 21' - 6"	6" STD.	5/8"	5/8"	B	3/4"	5/8"	B	1/2"	5/8"	C
4' - 4 1/2" X 17' - 6"	5" STD.	1/2"	1/2"	A	1/2"	1/2"	A	5/8"	1/2"	A
3' - 10 1/2" X 15' - 6"	4" STD.	1/2"	3/8"	A	1/2"	3/8"	A	1/2"	1/2"	A
3' - 4 1/2" X 13' - 6"	3-1/2" STD.	1/2"	1/4"	A	1/2"	1/4"	A	1/2"	1/4"	A

FOR SIGNS WITH LENGTHS UP TO 2 1/4 TIMES THEIR HEIGHT: (2-1/4 TO 1 ASPECT RATIO)

Sign size : No Greater Than	PIPE SIZE	35 PSF WIND LOAD			45 PSF WIND LOAD			55 PSF WIND LOAD		
		BOLT SIZE	PLATE THICKNESS	PLATE TYPE	BOLT SIZE	PLATE THICKNESS	PLATE TYPE	BOLT SIZE	PLATE THICKNESS	PLATE TYPE
7' - 4 1/2" X 16' - 7"	6" H.W.	1/2"	1/2"	A	1/2"	1/2"	A	1/2"	1/2"	A
6' - 4 1/2" X 14' - 4"	6" STD.	1/2"	1/2"	A	1/2"	1/2"	A	1/2"	1/2"	A
5' - 8 1/2" X 12' - 10"	5" STD.	1/2"	1/2"	A	1/2"	1/2"	A	1/2"	1/2"	A
5' - 4 1/2" X 12' - 1"	5" STD.	1/2"	3/8"	A	1/2"	3/8"	A	1/2"	3/8"	A
4' - 4 1/2" X 9' - 10"	4" STD.	3/8"	3/8"	A	3/8"	3/8"	A	3/8"	3/8"	A
3' - 4 1/2" X 7' - 7"	3" STD.	3/8"	1/4"	A	3/8"	1/4"	A	3/8"	1/4"	A

Note: Pipe sizes are based upon staging to a larger diameter pipe at a distance of 12 inches or less below the bottom of the sign cabinet

PIPE SIZES NOTED AS STD. ARE SCHEDULE 40 STRUCTURAL PIPE

PIPE SIZES NOTED AS H.W. ARE SCHEDULE 80 STRUCTURAL PIPE

NOTE: USE ASTM A-325 HARDENED BOLTS W/ DOUBLE WASHERS AND A-325 NUTS

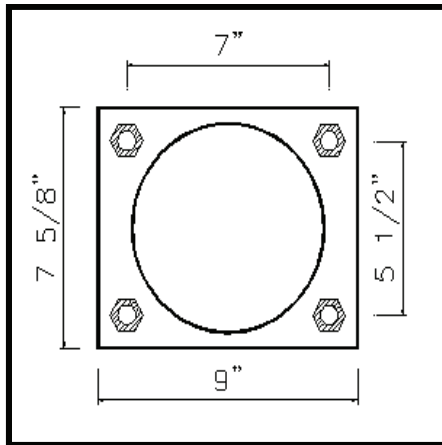

PLATE A

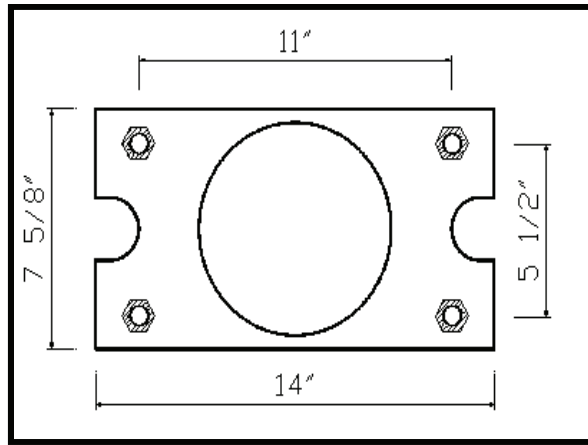

PLATE A

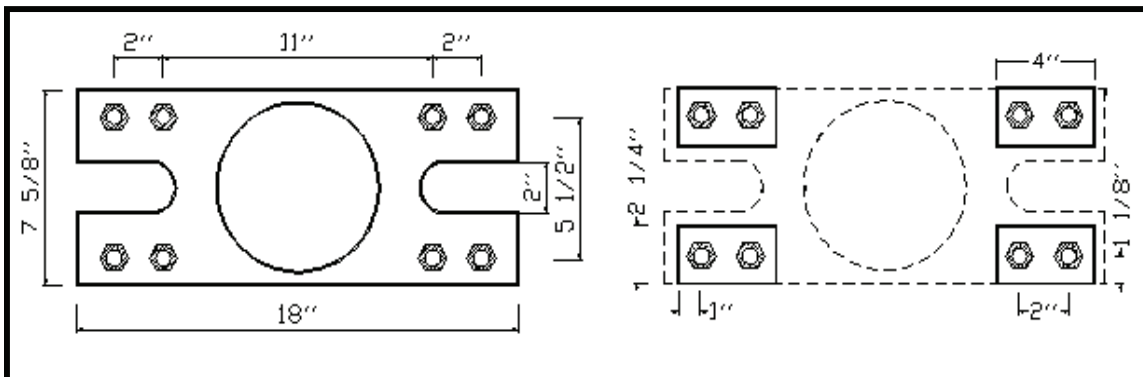

Plate thickness per charts above

Steel Plate 1/4 x 2 1/4 x 4 in.

PLATE C

BACKING PLATES FOR C

SUPPLEMENTAL STRUCTURAL GUIDELINES

**FOR SIGN SIZES LARGER THAN THOSE SHOWN ON THE PRECEDING CHARTS,
REFER STRUCTURAL DESIGN TO A LICENSED PROFESSIONAL STRUCTURAL ENGINEER.**

**** REQUIRED TORQUE ON GRADE 5 FASTENERS**

TORQUE: (FT-LB) BOLT DIAMETER PROOF LOAD

100 FT-LB	1/2 IN.	12,000#
200 FT-LB	5/8 IN.	19,000#
255 FT-LB	3/4 IN.	28,000#

PROVIDE HARDENED WASHERS, TYPICAL
WITH GRADE 5 BOLTS OR USE ASTM A-325 BOLTS.

**** NOTE:**

Do not weld aluminum within one inch of any bolt hole or other high-stress location.

Aluminum extrusions should be backed by steel plates or angles at points where diagonal truss cables attach at the outside lower corners of the sign cabinet.

Aluminum in contact with steel needs protection from electrolytic action: Use plated bolts and provide bitumastic paint, water-white methacrylate lacquer, or zinc chromate coating on surfaces of dissimilar metals in contact with each other.

**** NOTE:**

Proper friction connections require neatly fabricated holes in the aluminum and steel which are no larger than 1/32 inch over the bolt diameter. These holes should be free from burrs and carefully drilled for maximum strength.

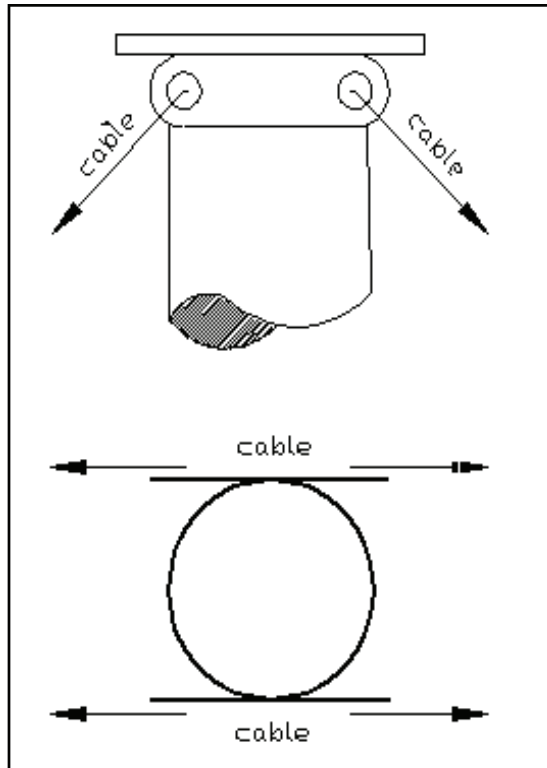

GUSSET PLATES

Gussets welded to pipe and to plate at abutment
(One On Each Side)

**** REGARDING CABLE EYES**

** Cables should be attached to gusset plates welded to side of center pipe & support plates. Support plate thicknesses for A, B, or C type plates should be increased by 1/8 inch minimum if cables are attached with bolts through cable eyes attached to connection plates. Bolt cable eyes in place and stitch weld cable eye to support / connection plate.

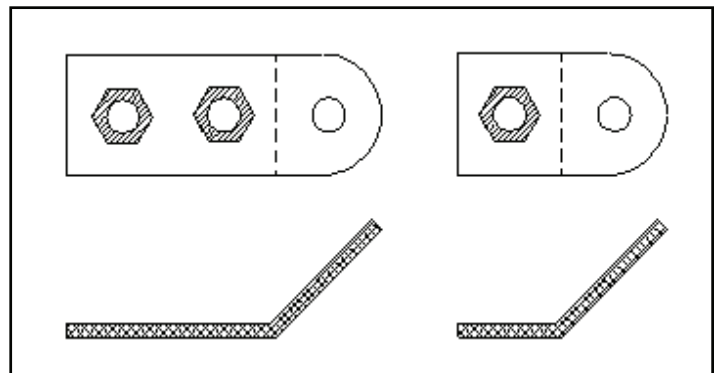

CABLE EYES

**** NOTE: FOR SIGNS WHICH ARE 1 1/2 TO 1 ASPECT RATIO OR LESS, USE CHART ON OPPOSITE PAGE FOR 2 1/4 TO 1 ASPECT RATIO WITH PLATE THICKNESS 1/8 IN. LESS (DO NOT USE ANY PLATE THICKNESS LESS THAN 1/4 INCH)**

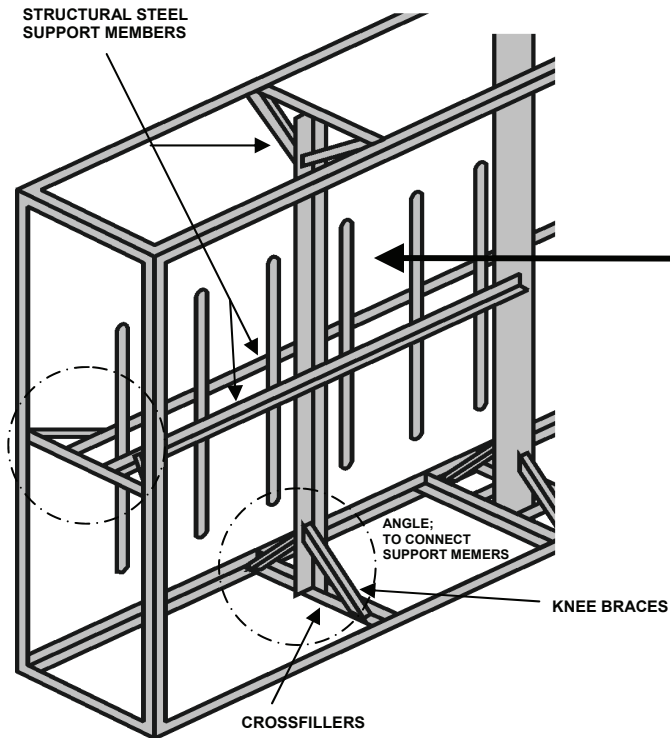

FOR TYPICAL STEEL ANGLE FRAME CONSTRUCTION:

The angle Iron frame illustration shows the typical knee braces that are required at the top and bottom of each strut member and for all horizontal struts or internal brace members. The cross members which connect the parallel frame side members at each strut add additional labor cost. The engineering data and illustrations show how much stronger ABC extruded aluminum frames are, compared to angle iron construction, and why ABC's A/Flexframes are so much more economical to build.

For double face signs with vertical lamps, place the support struts centered between the faces, parallel to the lamps, (fig. 1) or for horizontal lamping, place the struts in tandem just outside the lamps, (fig. 2)

Fig. 3 shows a typical C-Iron bolted to a Small A/Flexframe for a single face sign, with the strut at the back of the sign to prevent and shadows on the face. By making these types of brackets in quantity, so they are an off-the-shelf inventory item, saves a great deal of time and cost. All such brackets are to be bolted to the extruded aluminum frames following the guidelines on pages 3 and 4. The struts are then welded to the brackets as illustrated.

Fig. 4 illustrates ABC Cad-Cam cut aluminum plate C-Iron brackets which are cut to precisely fit the Single Hinge Frame for single face signs. Aluminum struts can be welded to these brackets. Steel struts must be double bolted, as illustrated.

Fig. 5 illustrates the same technique as used for rigid plastic face sign built of ABC's Conventional Frames.

ANGLE IRON FRAME TYPICAL KNEEBRACE TRUSS CONSTRUCTION

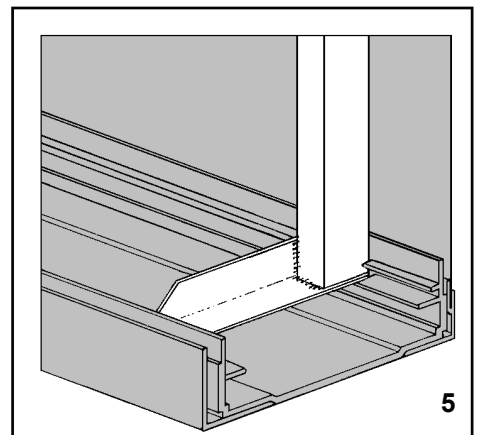
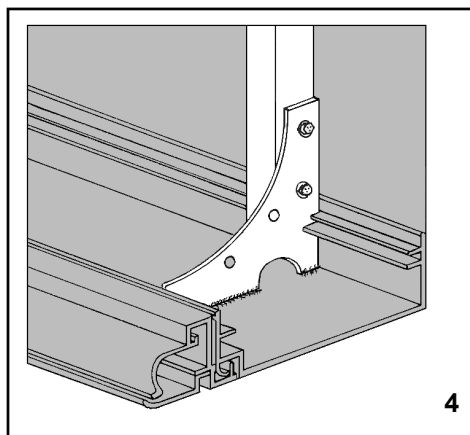
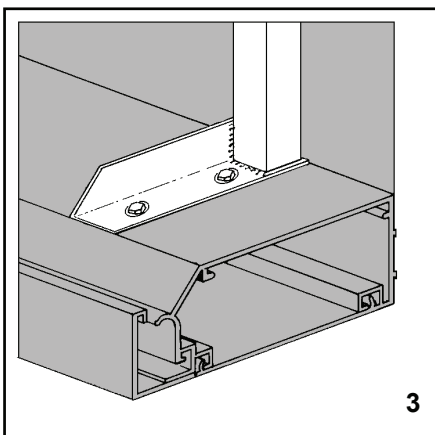
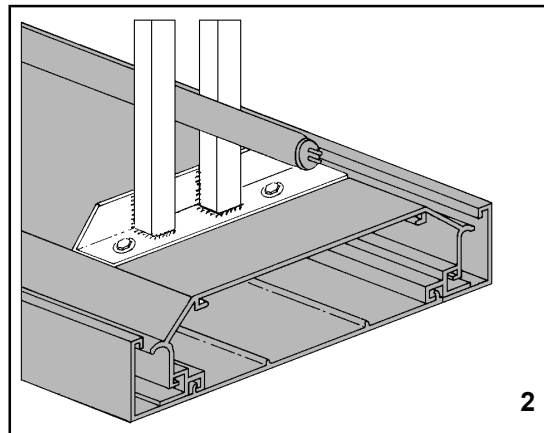
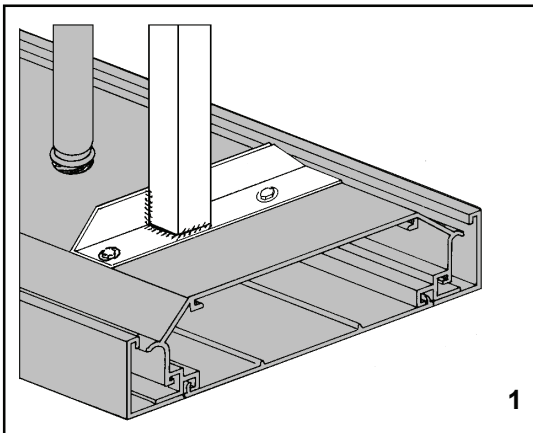

Have questions? Please call 1.800.248.9889. Our salespeople can help you through any project.
 web address: www.abcsignproducts.com email: abcsigns@abcsignproducts.com

The parts described on this page are covered by on or more of the following patents:
 U.S. 4,007,552 4,265,039
 CANADIAN 1,021,565 1,149,159 1,170,048 1,170,049 1,170,050



The attached Wind Pressure Charts are intended for use with the ABC Accutrack® Engineering software. They provide reliable wind pressure input values to use in conjunction with our software to create estimates of materials that will comply with requirements defined in the International Building Code. Pay especially close attention to using these charts when designing multiple-column sign support structures. Many municipalities have adopted the guidelines established by IBC 2003 (ASCE 7-02). Other cities have adopted the newer, IBC 2006 (ASCE 7-05) interpretations. Older codes may still allow structures designed to comply with guidelines established in the UBC (97). For this reason we have provided this flexible chart for software users in determining wind pressure values for Accutrack®.

Single-Pole structures are handled much as they were in older building codes. But with the IBC approach, two-pole structures that have commonly been used by US sign companies must now have larger diameter poles or square tubes, and deeper or wider footing dimensions resulting in higher costs of steel support columns and concrete for sign builders/installers. Approximating these costs with accuracy is essential for profitable outcome on many sign projects, and the software user should take care to use appropriate wind pressure values to comply with their governing sign code.

Ground Signs (Pylon Signs): are signs with skirts, pole-covers or pylon covers that start at the ground and with no appreciable amount of open space between the ground and top of the sign cabinet itself.

Above-Ground Signs (Freestanding Signs): are column-mounted signs that have little-or-no pole-covers, with substantial open area between the ground and the bottom of the sign cabinet.

The attached tables assume the following:

1. Height is the distance from the ground to the top of the sign.
2. Wind Speed is 3-second Gust, Exposure C is assumed.
3. Wind Pressures assume no topographical effects are present ($K_{zt} = 1.0$)
4. Gust effect Factor, G , assumed to be equal to 1.0
5. Two-pole designs:
 - a. B = Horizontal dimension of sign cabinet
 - b. Span Models where pipe centers are $= 2/3*B$; assume $1/6*B$ cantilever each end.
 - c. Span Models where pipe centers are $= 1/2*B$; assume $1/4 *B$ cantilever each end.

These Charts are recommended for Above-Ground Signs whose length does not exceed 4 times its height, and for Ground-Signs whose height does not exceed 5 times its width. For urban locations where careful surveys can confirm a sign location will have 2-story (or taller) structures within $\frac{1}{2}$ mile radius on all sides, the sign may qualify for Exposure B consideration. In this event, deduct 5 PSF from the values in the chart. This may not be appropriate for signs over 50 feet tall.

In general: two-pole designs for sign structures compliant with IBC guidelines will be less cost-competitive against viable center-column designs under the IBC, especially for signs over 30 feet tall. The IBC handles “unbalanced” loads (torsion forces) for multi-column designs differently as compared to older codes, and the newly-introduced “shape factors” in the IBC codes result in larger structural components. The proper handling of internal diagonal trussing in sign frames also helps to resist the unbalanced load. Please refer to ABC® EZ-Sheet 18 in the ABC® Product Catalog for design details.

Use this Chart if your local sign ordinance has adopted Guidelines established in IBC 2006 / ASCE 7-05

For Sign Cabinets with Width (Horizontal) / Height (Vertical) Dimension = 2

Center-Pole Ground Signs			
Height of Sign	90 MPH	100 MPH	110 MPH
15 to 30 Feet	26	33	39
31 to 50 Feet	29	36	44
51 to 100 Feet	33	42	51
101 to 150 Feet	37	46	55
151 to 200 Feet	39	49	59

2-Pole Ground Signs; Pole Spacing = 2/3 Length			
Height of Sign	90 MPH	100 MPH	110 MPH
15 to 30 Feet	43	53	64
31 to 50 Feet	48	59	71
51 to 100 Feet	55	68	82
101 to 150 Feet	60	74	90
151 to 200 Feet	64	79	95

2-Pole Ground Signs; Pole Spacing = 1/2 Length			
Height of Sign	90 MPH	100 MPH	110 MPH
15 to 30 Feet	48	59	72
31 to 50 Feet	54	66	80
51 to 100 Feet	62	76	93
101 to 150 Feet	68	83	101
151 to 200 Feet	72	89	107

Center-Pole Freestanding Signs			
Height of Sign	90 MPH	100 MPH	110 MPH
15 to 30 Feet	30	35	45
31 to 50 Feet	35	45	55
51 to 100 Feet	40	50	60
101 to 150 Feet	45	55	65
151 to 200 Feet	50	60	70

2-Pole Freestanding Signs; Spacing = 2/3 Length			
Height of Sign	90 MPH	100 MPH	110 MPH
15 to 30 Feet	50	61	74
31 to 50 Feet	55	68	83
51 to 100 Feet	64	79	96
101 to 150 Feet	70	86	104
151 to 200 Feet	74	91	111

2-Pole Freestanding Signs; Spacing = 1/2 Length			
Height of Sign	90 MPH	100 MPH	110 MPH
15 to 30 Feet	56	69	84
31 to 50 Feet	62	77	93
51 to 100 Feet	72	89	107
101 to 150 Feet	79	97	117
151 to 200 Feet	83	103	125

For Sign Cabinets with Width (Horizontal) / Height (Vertical) Dimension = 4

Center-Pole Ground Signs			
Height of Sign	90 MPH	100 MPH	110 MPH
15 to 30 Feet	26	33	39
31 to 50 Feet	29	36	44
51 to 100 Feet	33	42	51
101 to 150 Feet	37	46	55
151 to 200 Feet	39	49	59

2-Pole Ground Signs; Pole Spacing = 2/3 Length			
Height of Sign	90 MPH	100 MPH	110 MPH
15 to 30 Feet	42	52	63
31 to 50 Feet	47	58	70
51 to 100 Feet	54	67	81
101 to 150 Feet	59	73	88
151 to 200 Feet	63	78	94

2-Pole Ground Signs; Pole Spacing = 1/2 Length			
Height of Sign	90 MPH	100 MPH	110 MPH
15 to 30 Feet	47	59	71
31 to 50 Feet	53	65	79
51 to 100 Feet	61	75	91
101 to 150 Feet	67	82	99
151 to 200 Feet	71	87	106

Center-Pole Freestanding Signs			
Height of Sign	90 MPH	100 MPH	110 MPH
15 to 30 Feet	30	35	45
31 to 50 Feet	35	45	55
51 to 100 Feet	40	50	60
101 to 150 Feet	45	55	65
151 to 200 Feet	50	60	70

2-Pole Freestanding Signs; Spacing = 2/3 Length			
Height of Sign	90 MPH	100 MPH	110 MPH
15 to 30 Feet	51	63	76
31 to 50 Feet	57	70	85
51 to 100 Feet	66	81	98
101 to 150 Feet	72	89	107
151 to 200 Feet	76	94	114

2-Pole Freestanding Signs; Spacing = 1/2 Length			
Height of Sign	90 MPH	100 MPH	110 MPH
15 to 30 Feet	58	71	86
31 to 50 Feet	64	79	96
51 to 100 Feet	74	91	110
101 to 150 Feet	81	100	121
151 to 200 Feet	86	121	128

Use this Chart if your local sign ordinance has adopted Guidelines established in IBC 2003 / ASCE 7-02

For Ground Signs w/ Cabinets Height (Vertical) < or = 3 x Width (Horizontal)

Center-Pole Ground Signs			
Height of Sign	90 MPH	100 MPH	110 MPH
15 to 30 Feet	30	35	45
31 to 50 Feet	35	45	55
51 to 100 Feet	40	50	60
101 to 150 Feet	45	55	65
151 to 200 Feet	50	60	70

Two Pole Signs; Pole Spacing = 2/3 Length of Sign			
Height of Sign	90 MPH	100 MPH	110 MPH
15 to 30 Feet	33	41	50
31 to 50 Feet	37	46	55
51 to 100 Feet	43	53	64
101 to 150 Feet	47	57	70
151 to 200 Feet	49	61	74

Two Pole Signs; Pole Spacing = 1/2 Length of Sign			
Height of Sign	90 MPH	100 MPH	110 MPH
15 to 30 Feet	37	46	56
31 to 50 Feet	41	51	62
51 to 100 Feet	48	59	72
101 to 150 Feet	52	65	78
151 to 200 Feet	56	69	83

For Ground Signs w/ Cabinets Height (Vertical) > 3 but < or = 5 x Width (Horizontal)

Center-Pole Ground Signs			
Height of Sign	90 MPH	100 MPH	110 MPH
15 to 30 Feet	30	35	45
31 to 50 Feet	35	45	55
51 to 100 Feet	40	50	60
101 to 150 Feet	45	55	65
151 to 200 Feet	50	60	70

Two Pole Signs; Pole Spacing = 2/3 Length of Sign			
Height of Sign	90 MPH	100 MPH	110 MPH
15 to 30 Feet	36	44	54
31 to 50 Feet	40	49	60
51 to 100 Feet	47	57	69
101 to 150 Feet	50	62	75
151 to 200 Feet	54	66	80

Two Pole Signs; Pole Spacing = 1/2 Length of Sign			
Height of Sign	90 MPH	100 MPH	110 MPH
15 to 30 Feet	40	50	60
31 to 50 Feet	45	56	67
51 to 100 Feet	52	64	78
101 to 150 Feet	57	70	85
151 to 200 Feet	60	74	90

For Above-Ground Sign Cabinets with Width (Horizontal) Dimension < or = 6 x Height (Vertical)

Use this Chart for Freestanding Signs

Center-Pole Freestanding Signs			
Height of Sign	90 MPH	100 MPH	110 MPH
15 to 30 Feet	30	35	45
31 to 50 Feet	35	45	55
51 to 100 Feet	40	50	60
101 to 150 Feet	45	55	65
151 to 200 Feet	50	60	70

Two Pole Signs; Pole Spacing = 2/3 Length of Sign			
Height of Sign	90 MPH	100 MPH	110 MPH
15 to 30 Feet	33	41	50
31 to 50 Feet	37	46	55
51 to 100 Feet	43	53	64
101 to 150 Feet	47	57	70
151 to 200 Feet	49	61	74

Two Pole Signs; Pole Spacing = 1/2 Length of Sign			
Height of Sign	90 MPH	100 MPH	110 MPH
15 to 30 Feet	37	46	56
31 to 50 Feet	41	51	62
51 to 100 Feet	48	59	72
101 to 150 Feet	52	65	78
151 to 200 Feet	56	69	83

Use this Chart if your local sign ordinance has adopted Guidelines established in IBC 97 / ASCE 7-98

For Sign Cabinets with Any Aspect Ratio; for Ground Signs or Above-Ground (Freestanding) Signs

Center-Pole Freestanding Signs			
Height of Sign	90 MPH	100 MPH	110 MPH
15 to 30 Feet	30	35	45
31 to 50 Feet	35	45	55
51 to 100 Feet	40	50	60
101 to 150 Feet	45	55	65
151 to 200 Feet	50	60	70

Two Pole Signs; Pole Spacing = 2/3 Length of Sign			
Height of Sign	90 MPH	100 MPH	110 MPH
15 to 30 Feet	30	35	45
31 to 50 Feet	35	45	55
51 to 100 Feet	40	50	60
101 to 150 Feet	45	55	65
151 to 200 Feet	50	60	70

Two Pole Signs; Pole Spacing = 1/2 Length of Sign			
Height of Sign	90 MPH	100 MPH	110 MPH
15 to 30 Feet	30	35	45
31 to 50 Feet	35	45	55
51 to 100 Feet	40	50	60
101 to 150 Feet	45	55	65
151 to 200 Feet	50	60	70